

### C1 – Youth Showmanship

Be waiting at A.

1. Trot from A to B.
2. Stop at B and pivot 180 degrees.
3. Back to C.
4. Turn 180 degrees and walk to judge.
5. Stop and set up for inspection.
6. When indicated by the judge, turn 90 degrees and trot away.

*Line up on the right hand side of the arena (unless otherwise instructed by the ring steward).*

Walk	.....	Back	
Trot	- - - - -	Cone	▲

**Pattern Provided by:**  
*David Hudspeth*

### C2 – Open Showmanship

Pattern Provided by:  
*Mick Carder*

Walk	.....	Back	
Trot	- - - - -	Cone	▲

Be waiting at A.

1. Walk to the Judge.
2. Stop and set up for inspection.
3. When dismissed, perform a 450 degree turn.
4. Trot to B.
5. stop and back approximately 2 horse lengths.
6. Perform a 270 degree turn.
7. Trot straight away.

*Line up on the side wall as indicated (unless otherwise instructed by the ring steward).*

### C5 – Youth Horsemanship

Be ready at A.

1. Jog from A to B.
2. At B lope on a right lead and continue to C.
3. At C stop and back 4 steps.

*When indicated by the judge line up on the left wall of the arena, (unless otherwise instructed by the ring steward).*

Walk	.....	Lead change	▬
Jog	- - - - -	Back	
Extended Jog	- - - - -	Cone	▲
Lope	—————		

**Pattern Provided by:**  
*Sally Chamberlain*

### C6 — Youth Western Riding

**Pattern 1**

Walk	.....	Back	
Jog	- - - - -	Lead change	▬
Lope	—————	Cone	▲

Start

## C7 – Youth Reining

[Pattern 5]

Ride pattern as follows:

Begin at the centre of the arena facing the left wall or fence.

1. Beginning on the left lead, complete three circles to the left: the first two circles large and fast; the third circle small and slow. Stop at the centre of the arena.
2. Complete four spins to the left. Hesitate.
3. Beginning on the right lead, complete three circles to the right: the first two circles large and fast; the third circle small and slow. Stop at the centre of the arena.
4. Complete four spins to the right. Hesitate.
5. Beginning on the left lead, run a large fast circle to the left, change leads at the centre of the arena, run a large fast circle to the right, and change leads at the centre of the arena.
6. Continue around previous circle to the left but do not close this circle. Run up the right side of the arena past the centre marker and do a right rollback at least 20 feet from the wall or fence – no hesitation.
7. Continue around previous circle but do not close this circle. Run up the left side of the arena past the centre marker and do a left rollback at least 20 feet from the wall or fence – no hesitation.
8. Continue back around previous circle but do not close this circle. Run up the right side of the arena past the centre marker and do a sliding stop at least 20 feet from the wall or fence. Back up at least ten feet. Hesitate to demonstrate completion of pattern.

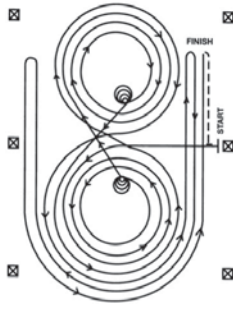

## C8 – Youth Versatile Horse

1. Open and pass through gate.
2. Jog over four poles.
3. Back through L, sidepass L shape (either way).
4. Lope on left lead.
5. Perform a serpentine around cones changing leads.
6. Extend the jog from A to B.
7. Jog from B to C.
8. Extend the jog from C to D.
9. Lope a half large fast circle to the right, then a small slow circle.
10. At E Stop, perform two spins to the right.
11. Lope on left led one small slow circle.
12. At F Stop, perform two spins to the left.
13. Lope on right lead with speed a 3/4 circle and run to the end cone and stop.
14. Back up a minimum of 10 feet.  
*Leave the arena.*

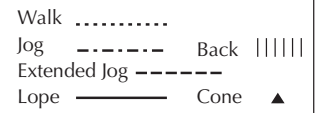
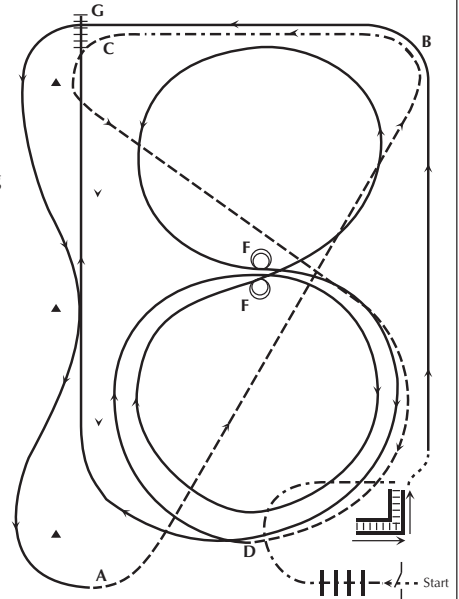

## C11 – Intermediate Amateur Horsemanship

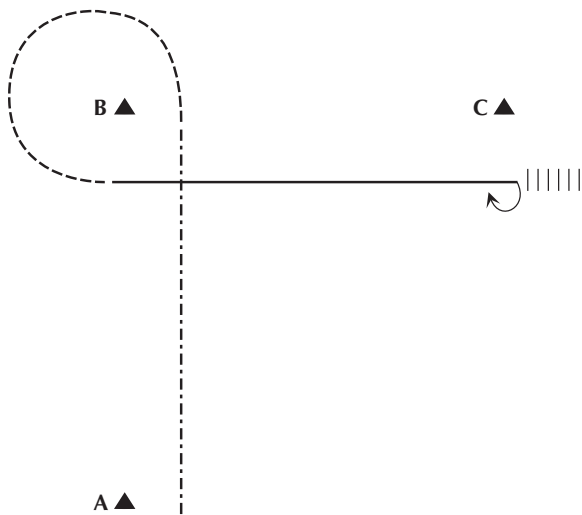

Be ready at A.

1. Jog from A to B.
2. At B extend the jog in a circle around B.
3. At B lope on a right lead to C.
4. Stop at C and perform a 180 degree turn to the right.
5. Back 4 steps.

When indicated by the judge line up at the entrance end of the arena, (unless otherwise instructed by the ring steward).

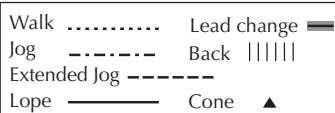

Pattern Provided by:  
**David Lloyd**

## C12 – AQHA Novice Amateur Horsemanship

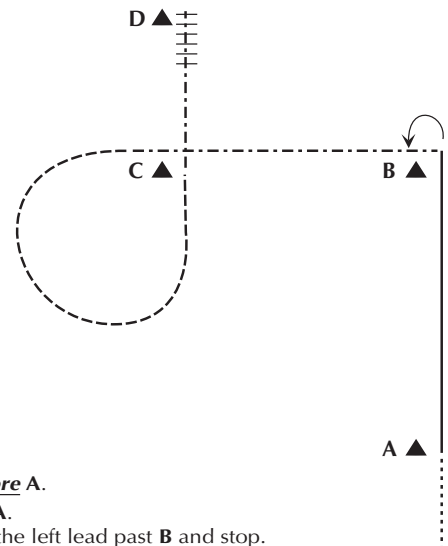

Be ready **before** A.

1. Walk to A.
2. Lope on the left lead past B and stop.
3. Turn 90 degrees to the left.
4. Jog from B to C.
5. Extend the jog in a circle around C.
6. Jog from C to D.
7. Stop at D and back approximately one horse length..

Line up on the left hand side wall of the arena, (unless otherwise instructed by the ring steward).

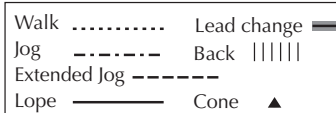

Pattern Provided by:  
**David Lloyd**

### C13 – Intermediate Amateur Reining

[Pattern 4]

Ride pattern as follows:

Begin at the centre of the arena facing the left wall or fence.

1. Beginning on the right lead, complete three circles to the right: the first two circles large and fast; the third circle small and slow. Stop at the centre of the arena.
2. Complete four spins to the right. Hesitate.
3. Beginning on the left lead, complete three circles to the left: the first two circles large and fast; the third circle small and slow. Stop at the centre of the arena.
4. Complete four spins to the left. Hesitate.
5. Beginning on the right lead, run a large fast circle to the right, change leads at the centre of the arena, run a large fast circle to the left, and change leads at the centre of the arena. (Figure 8)
6. Continue around previous circle to the right. At the top of the circle, run down the middle to the far end of the arena past the end marker and do a right rollback – no hesitation.
7. Run up the middle to the opposite end of the arena past the end marker and do a left rollback – no hesitation.
8. Run past the centre marker and do a sliding stop. Back up to the centre of the arena or at least ten feet. Hesitate to demonstrate completion of the pattern.

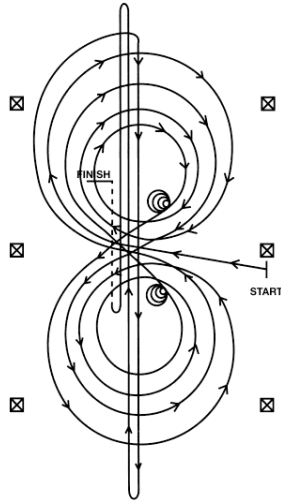

### C14 – AQHA Novice Amateur Reining

[Pattern 2]

Ride pattern as follows:

Begin at the centre of the arena facing the left wall or fence

1. Beginning on the right lead, complete three circles to the right: the first circle small and slow; the next two large and fast. Change leads at the centre of the arena.
2. Complete three circles to the left: the first circle small and slow; the next two large and fast. Change leads at the centre of the arena.
3. Continue around previous circle to the right. At the top of the circle, run down the middle to the far end of the arena past the end marker and do a right rollback – no hesitation
4. Run up the middle to the opposite end of the arena past the end marker and do a left rollback – no hesitation.
5. Run past the centre marker and do a sliding stop. Back up to the centre of the arena or at least ten feet. Hesitate.
6. Complete four spins to the right.
7. Complete four spins to the left. Hesitate to demonstrate the completion of the pattern.

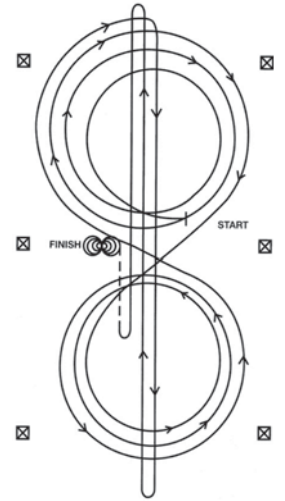

### C15 & 16 — Inter. Am. & AQHA Nov Am. WR

Pattern 1

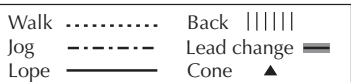
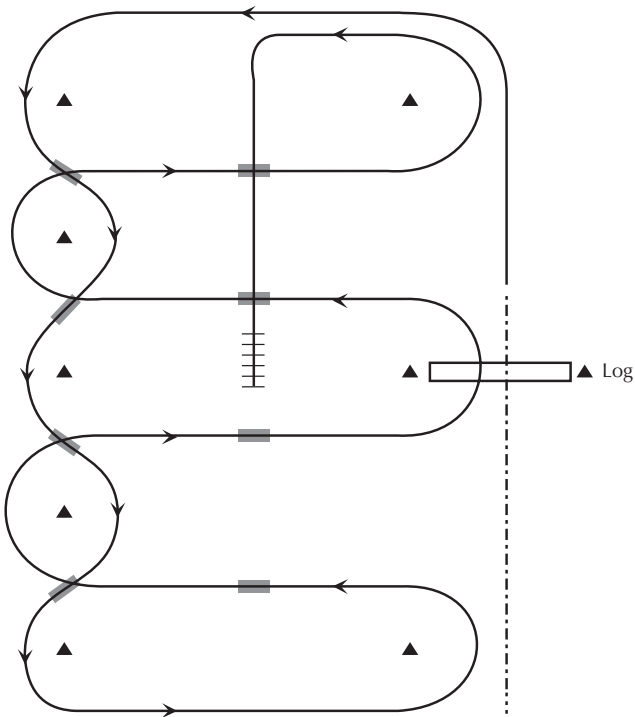

### C17 – Intermediate Amateur Versatile Horse

1. Open and pass through gate.
2. Jog over four poles.
3. Back through L, sidepass L shape (either way).
4. Lope on left lead.
5. Perform a serpentine around cones changing leads.
6. Extend the jog from A to B.
7. Jog from B to C.
8. Extend the jog from C to D.
9. Lope a half large fast circle to the right, then a small slow circle.
10. At E Stop, perform two spins to the right.
11. Lope on left led one small slow circle.
12. At F Stop, perform two spins to the left.
13. Lope on right lead with speed a 3/4 circle and run to the end cone and stop.
14. Back up a minimum of 10 feet.  
*Leave the arena.*

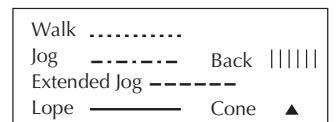
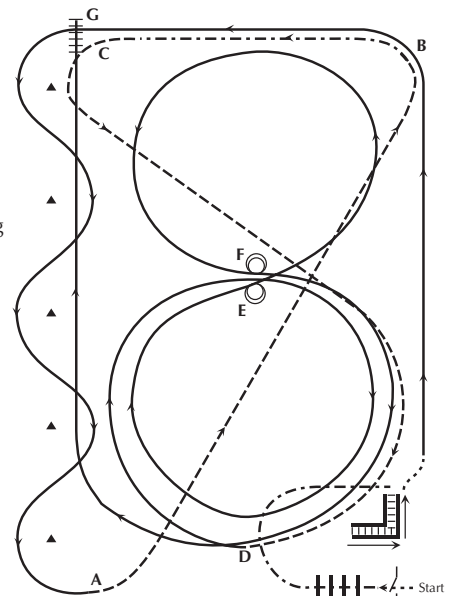

### C18 – AQHA Novice Amateur Trail

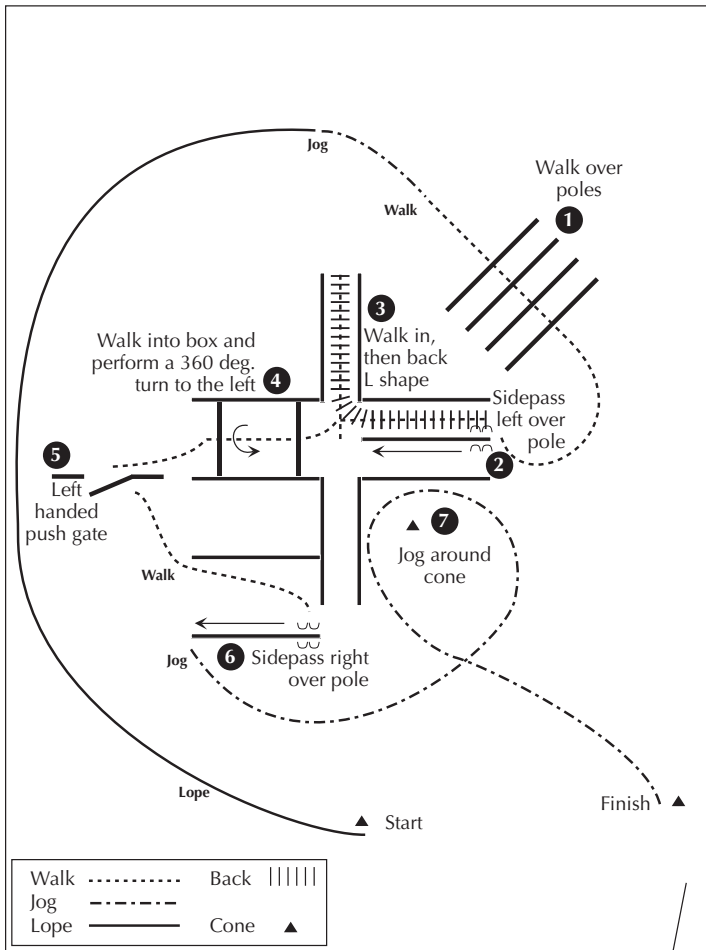

### C20 – Open Horsemanship

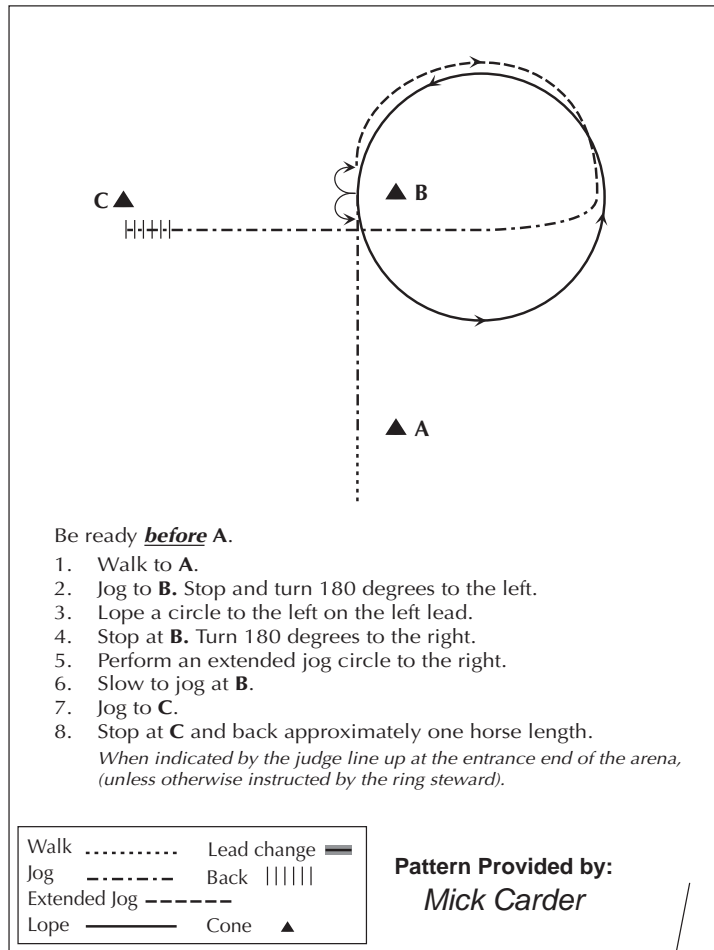

### C21 – Open Reining

#### PATTERN 3

Ride pattern as follows:

1. Beginning, at least 20 feet from the wall or fence, lope straight up the left side of the arena, circle the top end of the arena, run straight down the opposite side of the arena past the centre marker and do a left rollback no hesitation.
  2. Continue straight up the right side of the arena staying at least 20 feet from the wall or fence, circle back around the top of the arena, run straight down the left side of the arena past the centre marker and do a right rollback – no hesitation.
  3. Continue up the left side of the arena to the centre marker. At the centre marker, the horse should be on the right lead. Guide the horse to the centre of the arena on the right lead and complete three circles to the right: the first two large and fast; the third small and slow. Change leads at the centre of the arena.
  4. Complete three circles to the left: the first two large and fast; the third small and slow. Change leads in the centre of the arena.
  5. Begin a large fast circle to the right but do not close this circle. Continue up the left side of the arena staying at least 20 feet from the wall or fence, circle the top of the arena, run straight down the opposite side of the arena past the centre marker and do a sliding stop. Back up at least ten feet. Hesitate.
  6. Complete four spins to the right.
  7. Complete four spins to the left. Hesitate to demonstrate completion of pattern.
- 

### C22 — Open Western Riding

#### Pattern 4

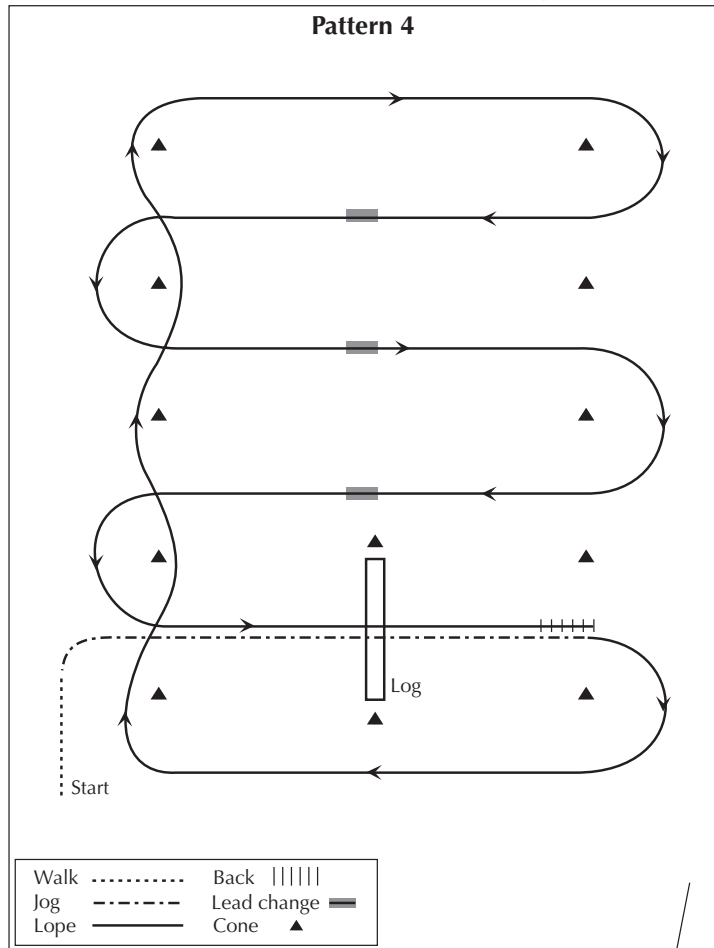

### C23 – Open Versatile Horse

1. Open and pass through gate.
2. Jog over four poles.
3. Back through L, sidepass L shape (either way).
4. Lope on left lead.
5. Perform a serpentine around cones changing leads.
6. Extend the jog from A to B.
7. Jog from B to C.
8. Extend the jog from C to D.
9. Lope a half large fast circle to the right, then a small slow circle.
10. At E Stop, perform two spins to the right.
11. Lope on left led one small slow circle.
12. At F Stop, perform two spins to the left.
13. Lope on right lead with speed a 3/4 circle and run to the end cone and stop.
14. Back up a minimum of 10 feet.  
*Leave the arena.*

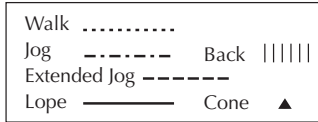
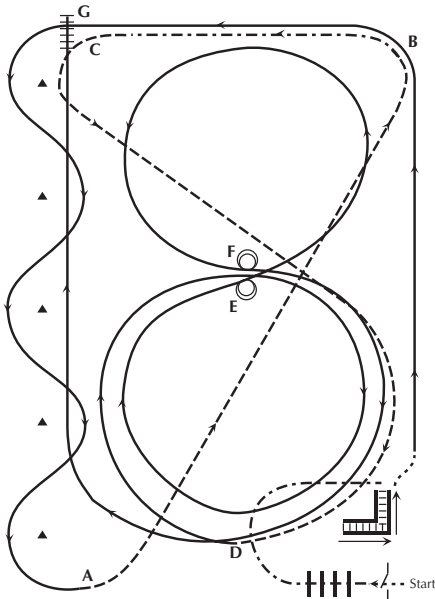

### C25 – Intermediate Amateur Trail

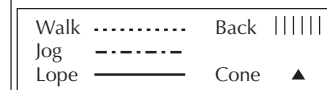
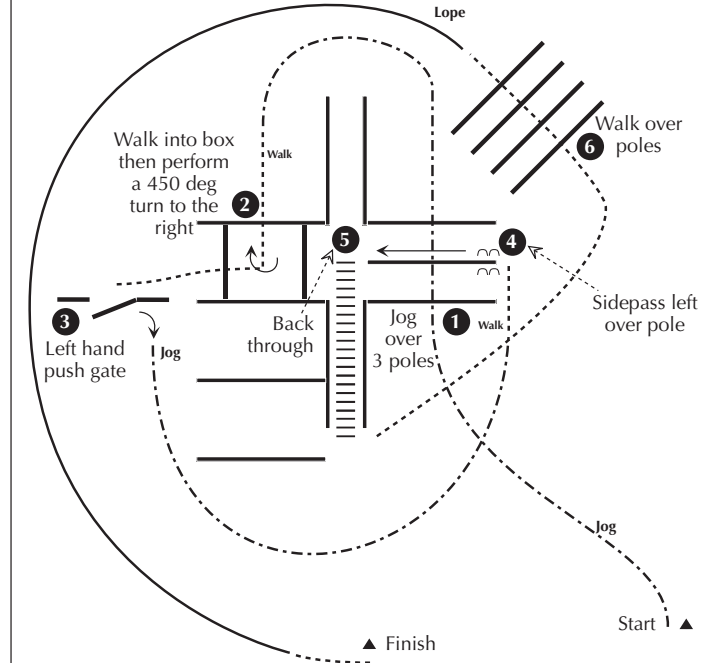

### C26 – Open Trail

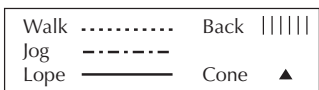
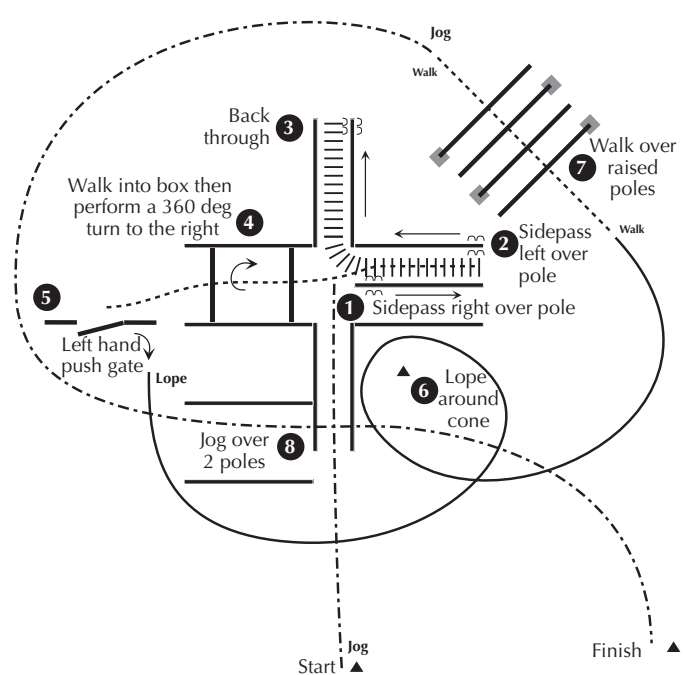

### C27 – Novice Youth Trail

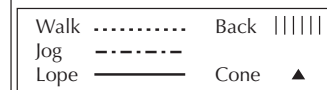
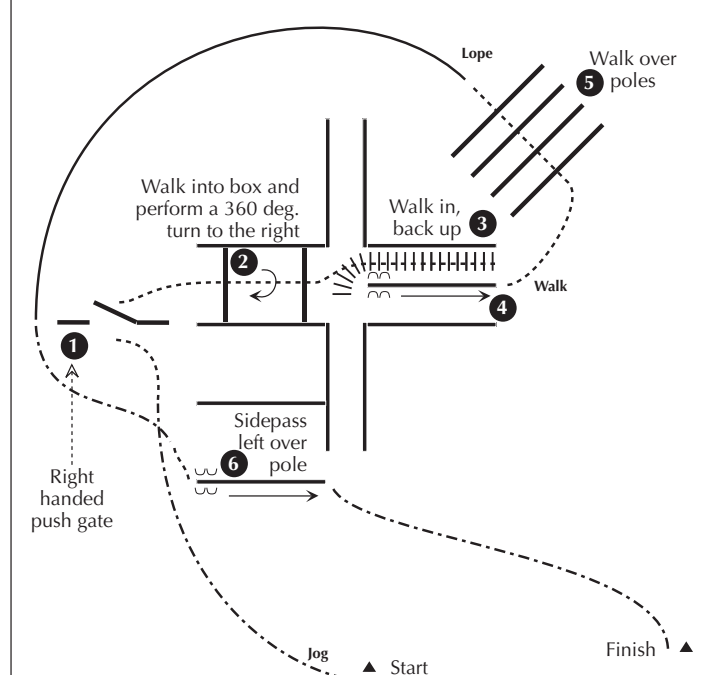

### C28 – Youth Trail

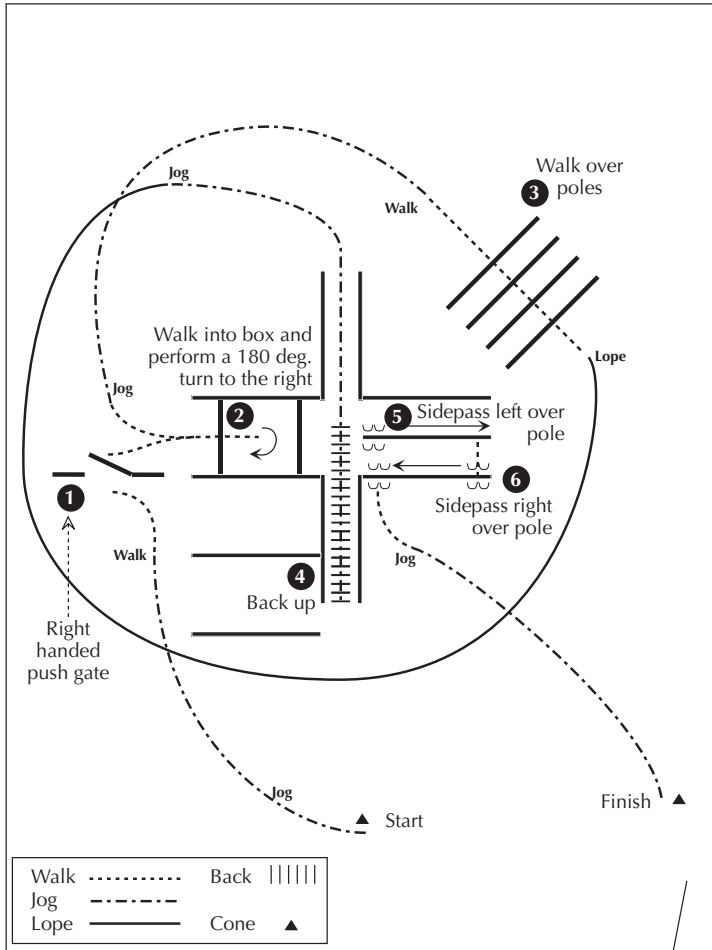

### C29 – Novice Rider Trail

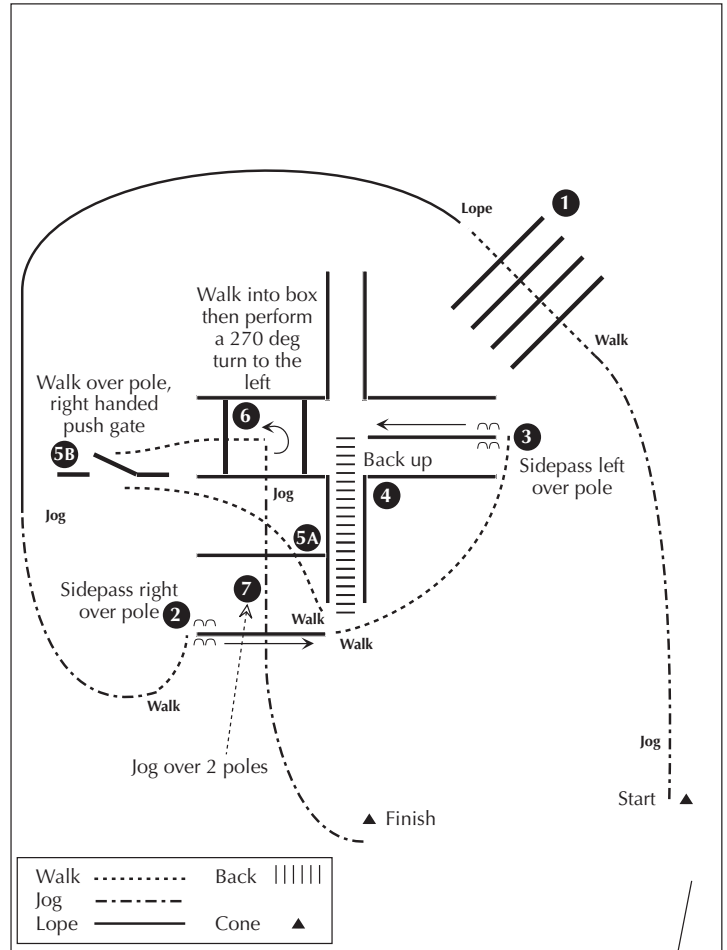

### C30 – Novice Rider Reining

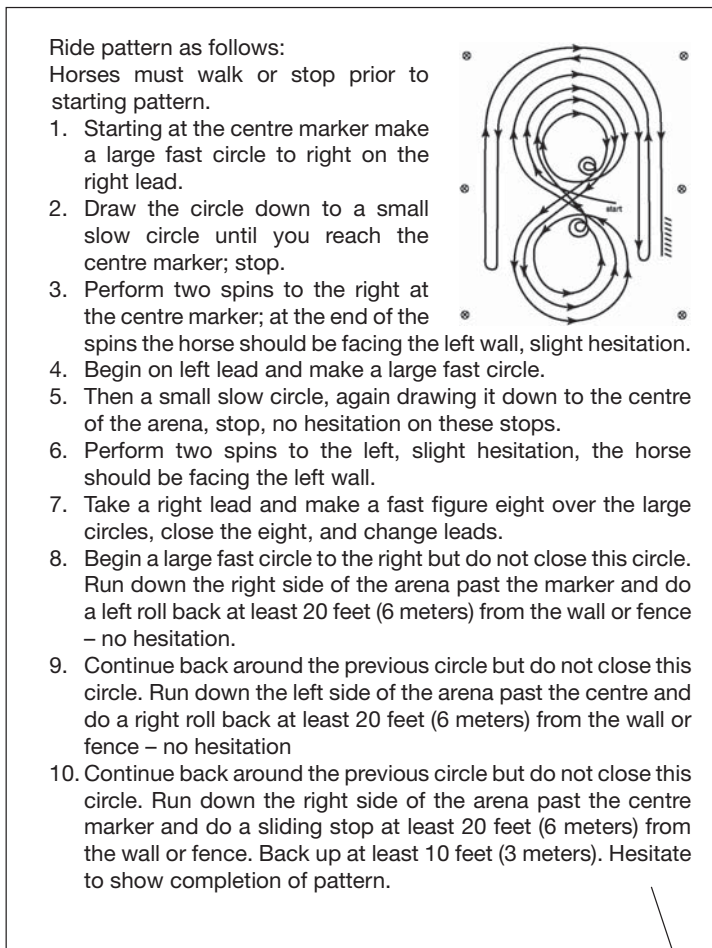

### C31 – Amateur Showmanship

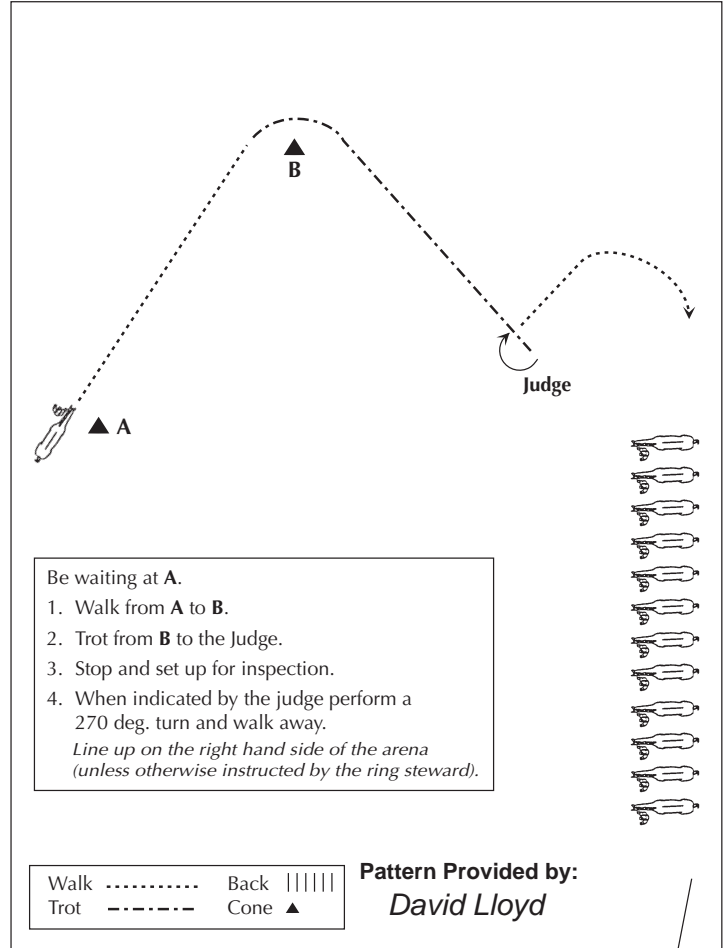

### C32 – Championship Showmanship

Be ready at **A**.

1. Trot halfway to **B**.
2. Walk two horse lengths.
3. Trot to and around **B** as shown.
4. Trot past **B** and stop. Perform a 360 degree turn.
5. Walk to judge and set up for inspection.
6. When dismissed, perform a 90 degree turn and back approximately 2 horse lengths.
7. Perform a 180 degree turn and walk straight away.

*Line up at the entrance end of the arena (unless otherwise instructed by the ring steward).*

Walk	.....	Back	
Trot	- - - - -	Cone	▲

Pattern Provided by:  
**Mick Carder**

### C34 – Novice Rider Horsemanship

Be ready at **A**.

1. Jog from **A** to **B**.
2. At **B** lope on a right lead and continue to **C**.
3. At **C** stop and back 4 steps.

*When indicated by the judge line up on the left wall of the arena, (unless otherwise instructed by the ring steward).*

Walk	.....	Lead change	==
Jog	- - - - -	Back	
Extended Jog	- - - - -		
Lope	—————	Cone	▲

Pattern Provided by:  
**Sally Chamberlain**

### C35 – Novice Rider Western Riding

**Pattern 5**

Start

Walk	.....	Back	
Jog	- - - - -	Lead change	==
Lope	—————	Cone	▲

### C36 – Novice Rider Versatile Horse

1. Open and pass through gate.
2. Jog over four poles.
3. Back through L, sidepass L shape (either way).
4. Lope on left lead.
5. Perform a serpentine around cones changing leads.
6. Extend the jog from **A** to **B**.
7. Jog from **B** to **C**.
8. Extend the jog from **C** to **D**.
9. Lope a half large fast circle to the right, then a small slow circle.
10. At **E** Stop, perform two spins to the right.
11. Lope on left led one small slow circle.
12. At **F** Stop, perform two spins to the left.
13. Lope on right lead with speed a 3/4 circle and run to the end cone and stop.
14. Back up a minimum of 10 feet.

*Leave the arena.*

Walk	.....	Back	
Jog	- - - - -		
Extended Jog	- - - - -	Cone	▲
Lope	—————		

### C39 – ApHC USA Trail

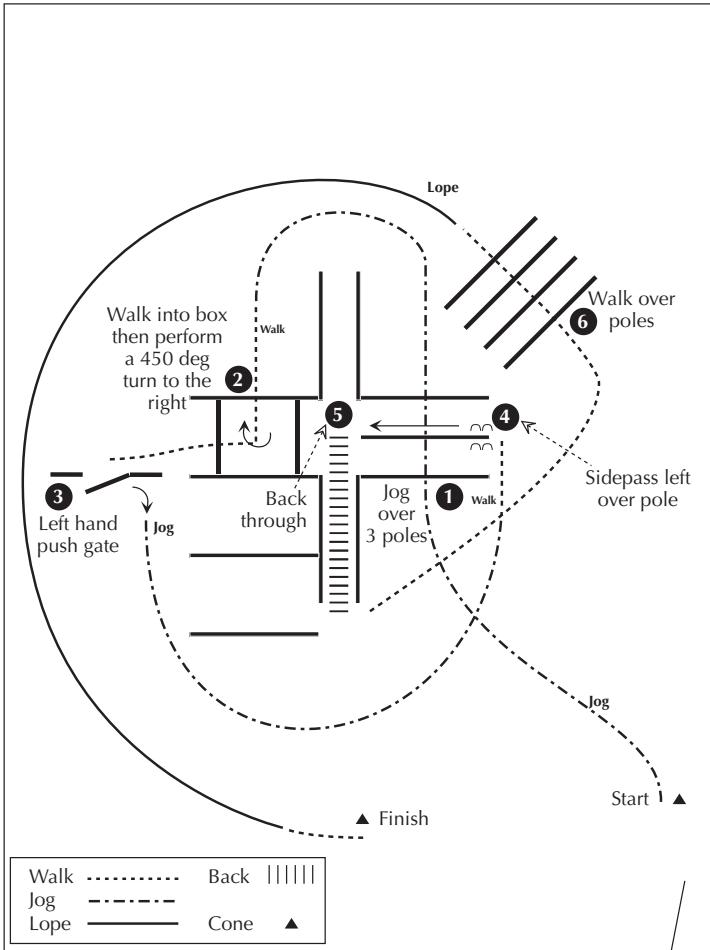

### C40 – Championship Trail

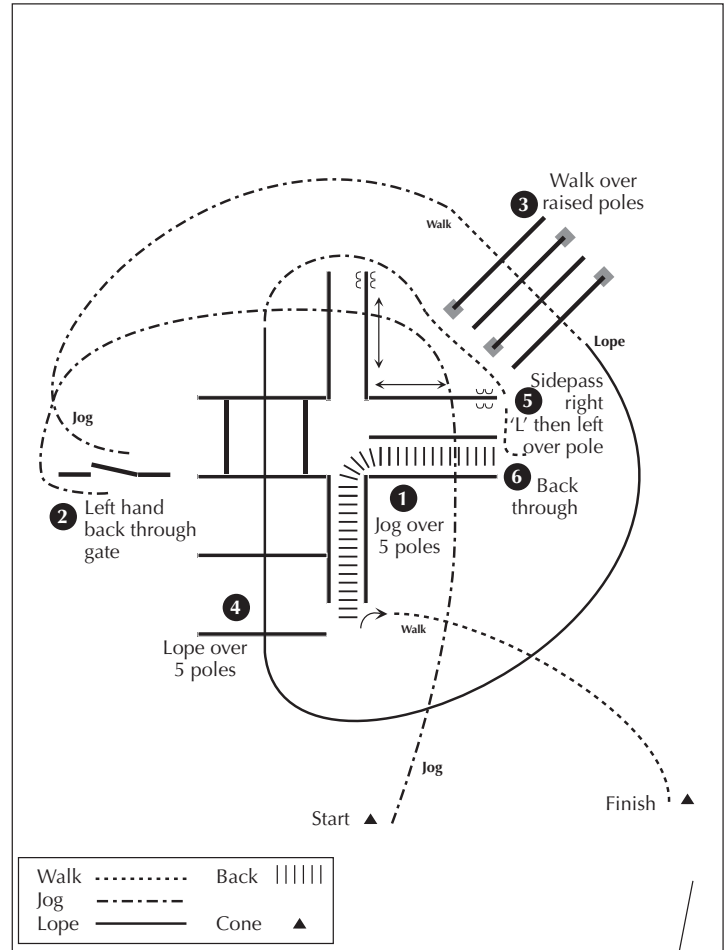

### C41 – Championship Horsemanship

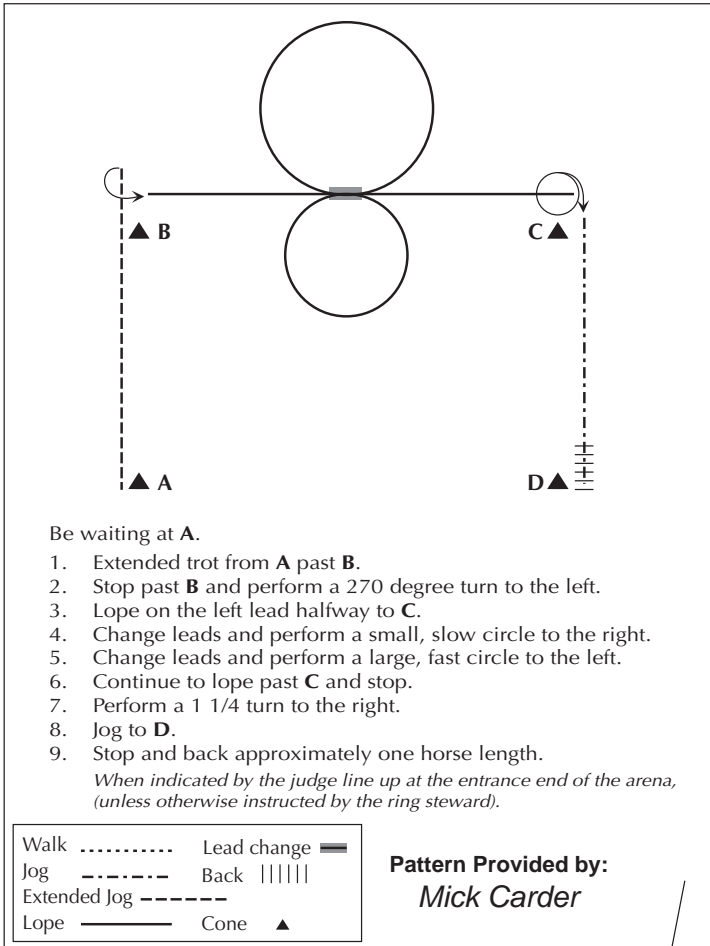

### C43 – Championship Reining

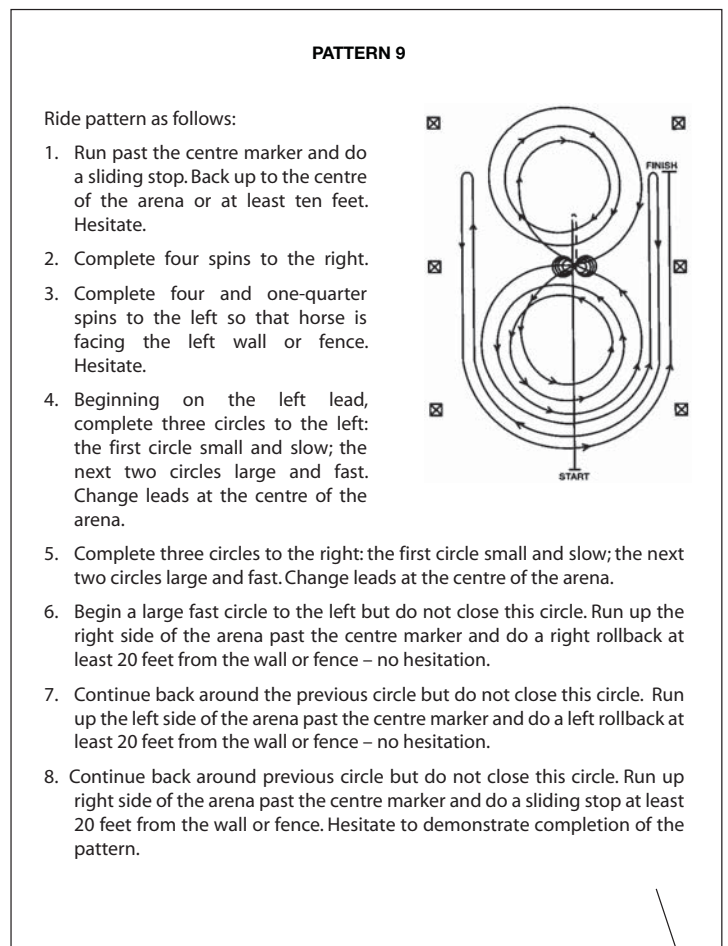

### C44 — Championship Western Riding

#### Pattern 3

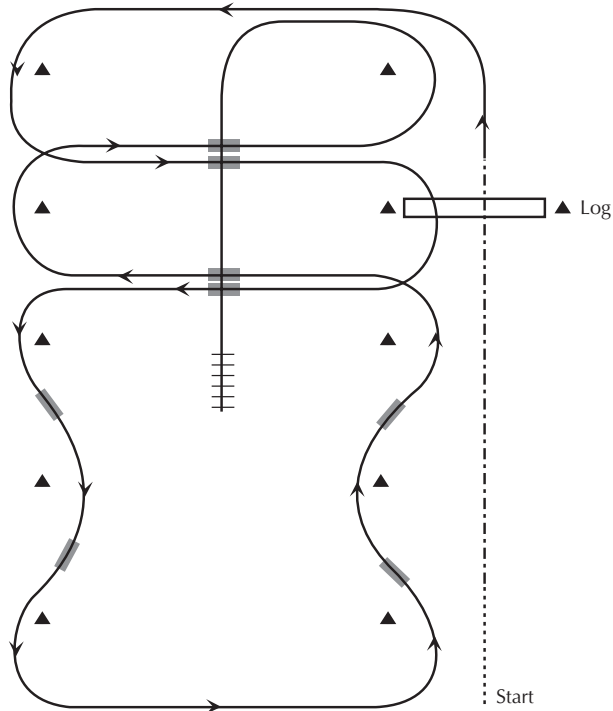

Walk	.....	Back	
Jog	- - - - -	Lead change	==
Lope	—————	Cone	▲

### C45 – Championship Versatile Horse

1. Open and pass through gate.
  2. Jog over four poles.
  3. Back through L, sidepass L shape (either way).
  4. Lope on left lead.
  5. Perform a serpentine around cones changing leads.
  6. Extend the jog from A to B.
  7. Jog from B to C.
  8. Extend the jog from C to D.
  9. Lope a half large fast circle to the right, then a small slow circle.
  10. At E Stop, perform two spins to the right.
  11. Lope on left led one small slow circle.
  12. At F Stop, perform two spins to the left.
  13. Lope on right lead with speed a 3/4 circle and run to the end cone and stop.
  14. Back up a minimum of 10 feet.
- Leave the arena.*

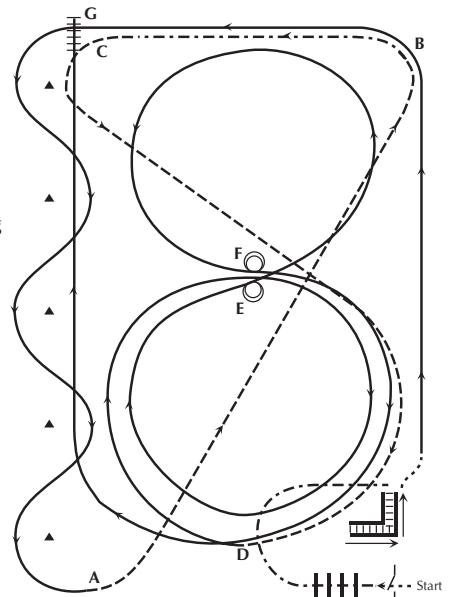

Walk	.....	Back	
Jog	- - - - -	Back	
Extended Jog	- - - - -		
Lope	—————	Cone	▲

### C68 – Amateur Trail

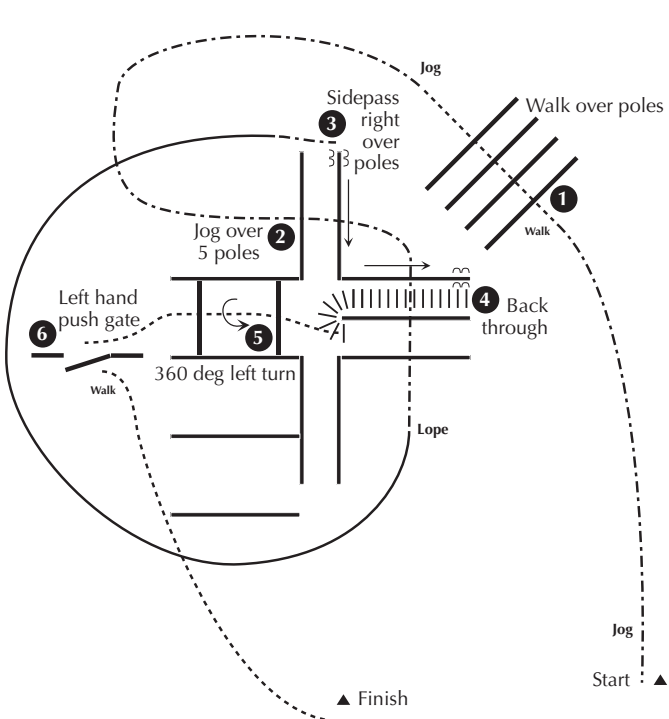

Walk	.....	Back	
Jog	- - - - -	Cone	▲
Lope	—————		

### C69 – Novice Horse Trail

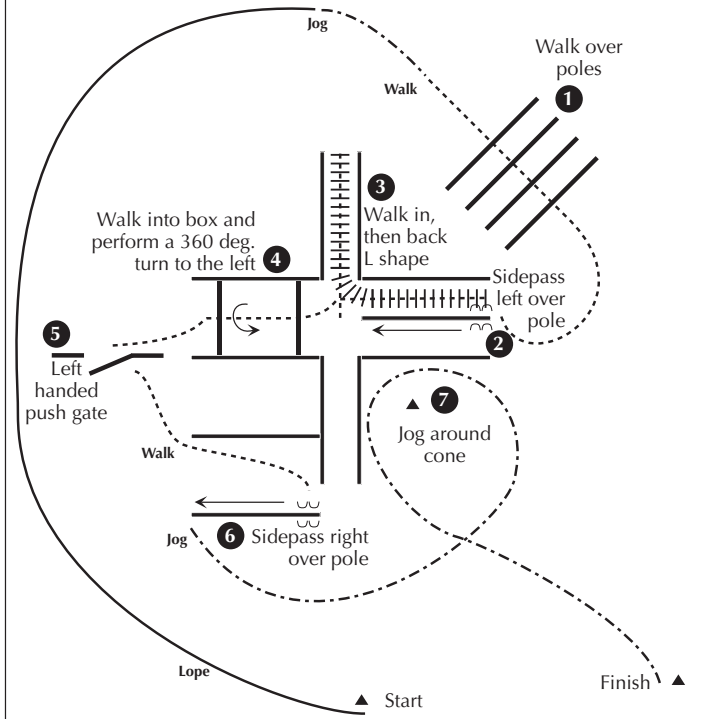

Walk	.....	Back	
Jog	- - - - -	Cone	▲
Lope	—————		

### C70 – APHA Trail all ages

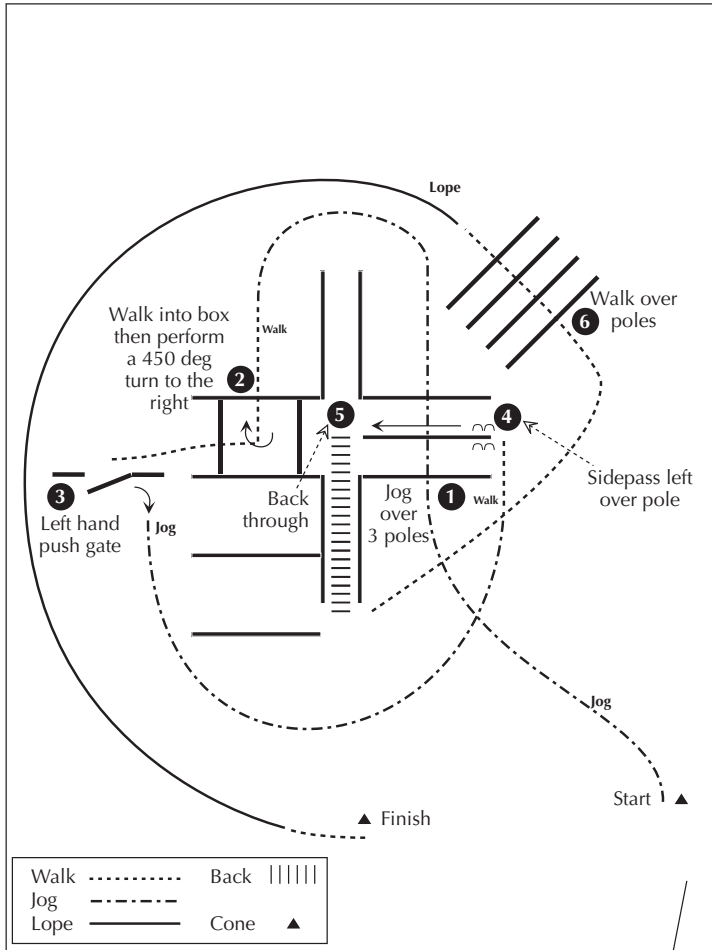

### C71 – SPB Trail all ages

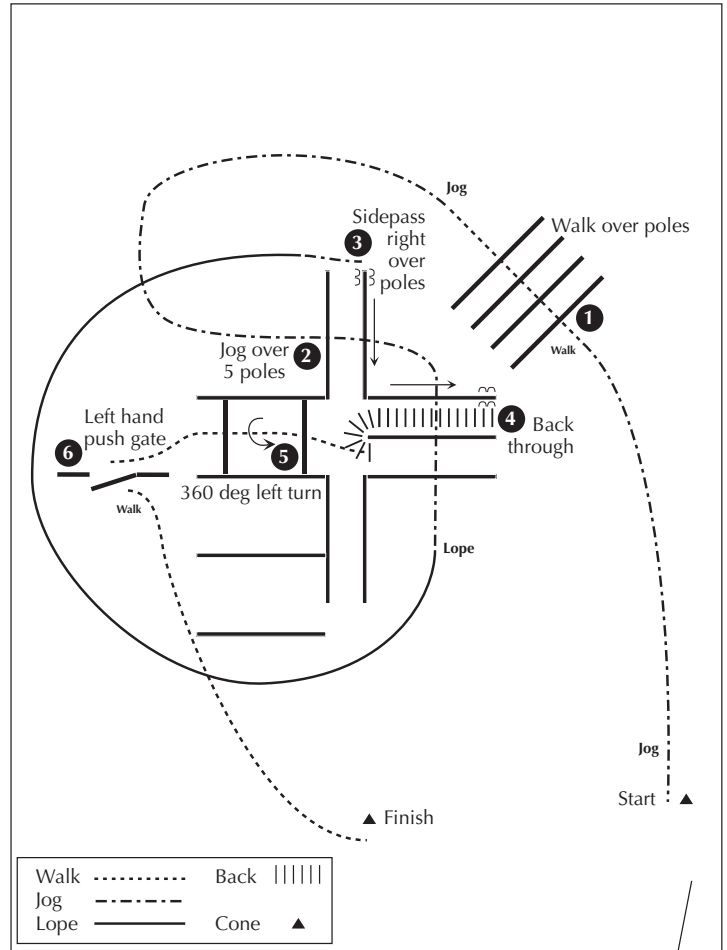

### C75-77 — Nov. Horse, APHA all ages & BWR1 All ages WR

#### Pattern 1

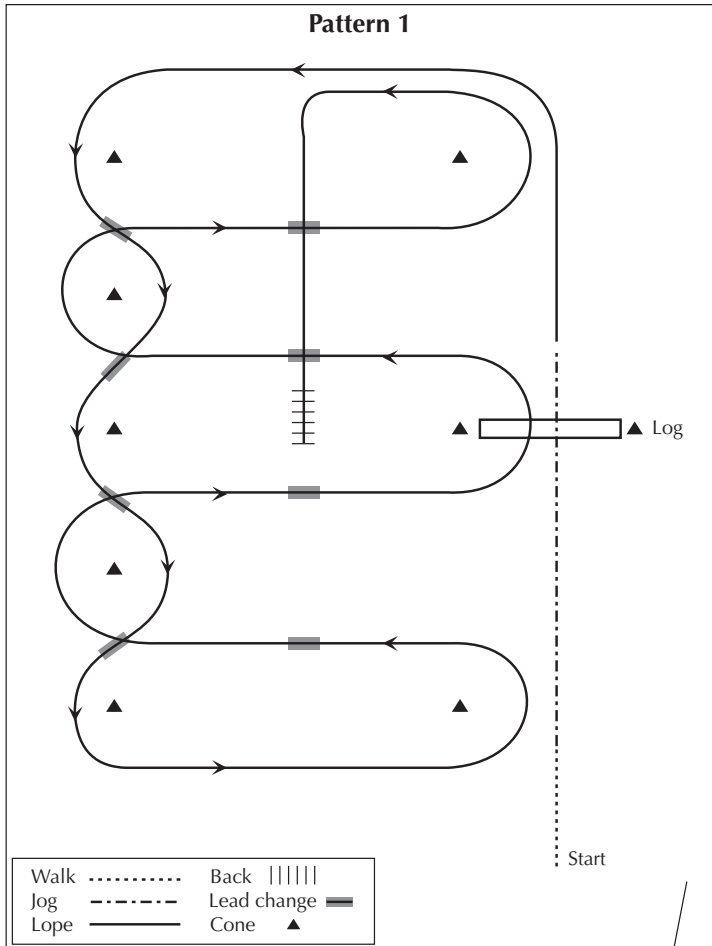

### C78 – Novice Horse Versatile Horse

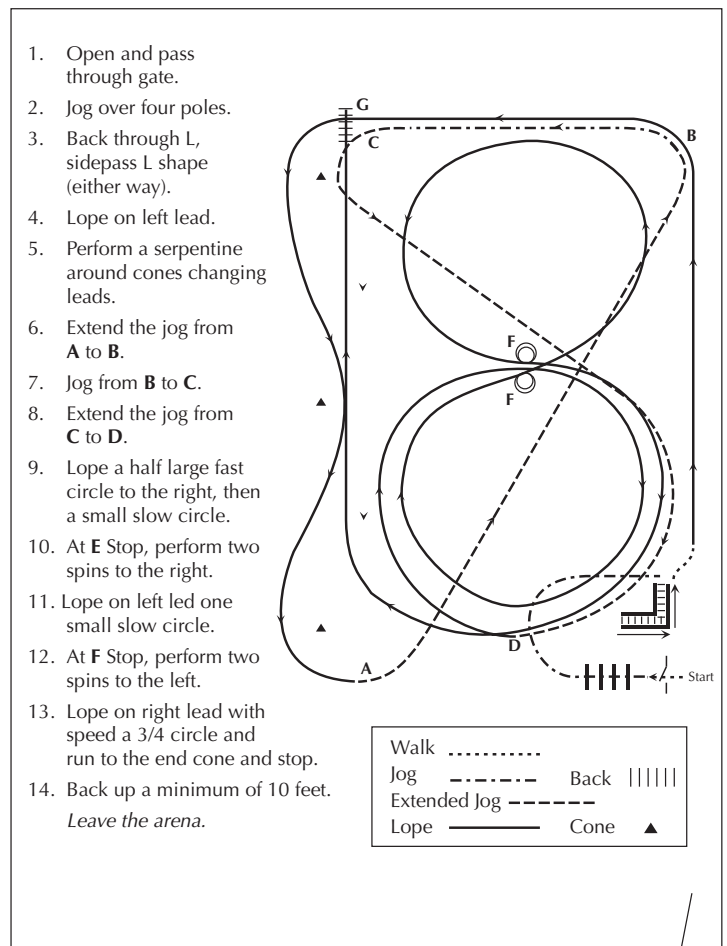

C79-81 – Nov. Horse, APHA all ages & SPB all ages Reining

[Pattern 2]

Ride pattern as follows:

Begin at the centre of the arena facing the left wall or fence

1. Beginning on the right lead, complete three circles to the right: the first circle small and slow; the next two large and fast. Change leads at the centre of the arena.
2. Complete three circles to the left: the first circle small and slow; the next two large and fast. Change leads at the centre of the arena.
3. Continue around previous circle to the right. At the top of the circle, run down the middle to the far end of the arena past the end marker and do a right rollback – no hesitation
4. Run up the middle to the opposite end of the arena past the end marker and do a left rollback – no hesitation.
5. Run past the centre marker and do a sliding stop. Back up to the centre of the arena or at least ten feet. Hesitate.
6. Complete four spins to the right.
7. Complete four spins to the left. Hesitate to demonstrate the completion of the pattern.

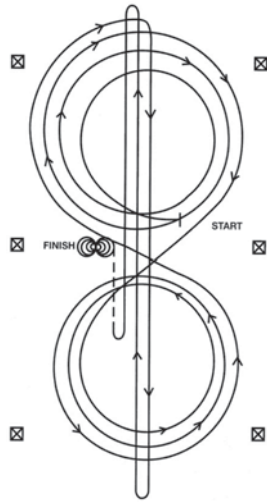

C83 – Amateur Horsemanship

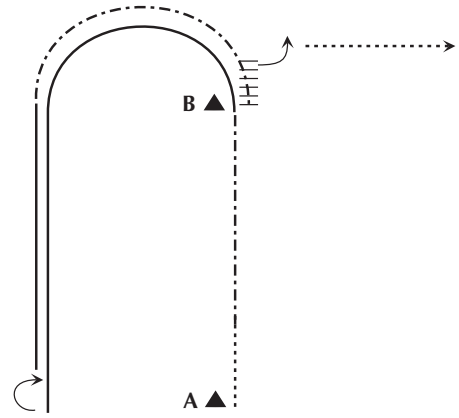

Be waiting at A.

1. Walk approximately 2 horse lengths from A.
2. Jog to B.
3. Lope on the left lead a half circle and then straight until even with A.
4. Stop and perform a 180 degree turn to the right.
5. Lope on the right lead until even with B.
6. Jog to B.
7. Stop at B and back approximately one horse length.
8. Perform a 90 degree turn to the left and walk straight away.

Line up on the right hand side wall of the arena, (unless otherwise instructed by the ring steward).

Walk	.....	Lead change	==
Jog	- - - - -	Back	
Extended Jog	- - - - -		
Lope	—————	Cone	▲

Pattern Provided by:  
David Lloyd

C84 – Amateur Reining

[Pattern 7]

Ride pattern as follows:

1. Run at speed to the far end of the arena past the end marker and do a left rollback – no hesitation.
2. Run to the opposite end of the arena past the end marker and do a right rollback – no hesitation.
3. Run past the centre marker and do a sliding stop. Back up to the centre of the arena at least ten feet. Hesitate.
4. Complete four spins to the right.
5. Complete four and one-quarter spins to the left so that horse is facing the left wall or fence. Hesitate.
6. Beginning on the right lead, complete three circles to the right: the first two circles large and fast; the third small and slow. Change leads at the centre of the arena.
7. Complete three circles to the left: the first two circles large and fast; the third circle small and slow. Change leads at the centre of the arena.
8. Begin a large fast circle to the right but do not close this circle. Run straight down the right side of the arena past the centre marker and do a sliding stop at least 20 feet from the wall or fence. Hesitate to demonstrate completion of the pattern.

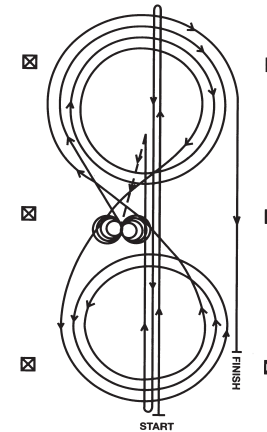

C85 — Amateur Western Riding

Pattern 4

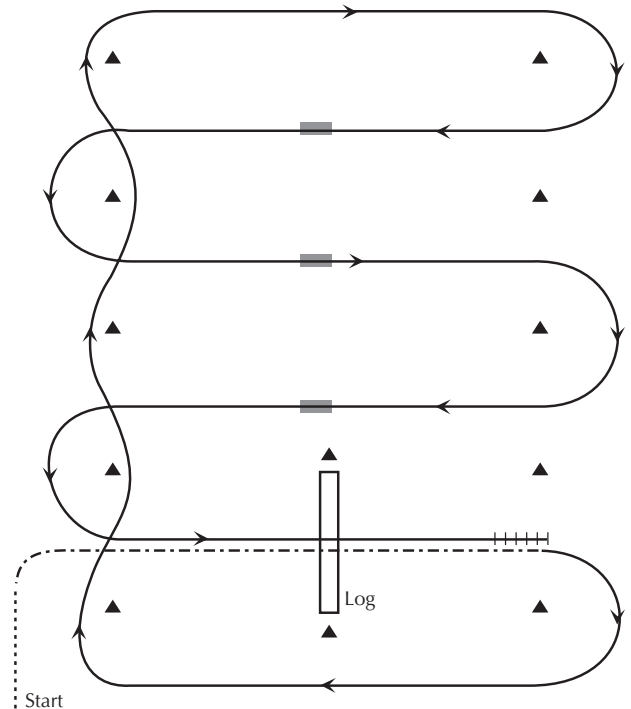

Walk	.....	Back	
Jog	- - - - -	Lead change	==
Lope	—————	Cone	▲

## C86 – Amateur Versatile Horse

1. Open and pass through gate.
2. Jog over four poles.
3. Back through L, sidepass L shape (either way).
4. Lope on left lead.
5. Perform a serpentine around cones changing leads.
6. Extend the jog from **A** to **B**.
7. Jog from **B** to **C**.
8. Extend the jog from **C** to **D**.
9. Lope a half large fast circle to the right, then a small slow circle.
10. At **E** Stop, perform two spins to the right.
11. Lope on left led one small slow circle.
12. At **F** Stop, perform two spins to the left.
13. Lope on right lead with speed a 3/4 circle and run to the end cone and stop.
14. Back up a minimum of 10 feet.  
*Leave the arena.*

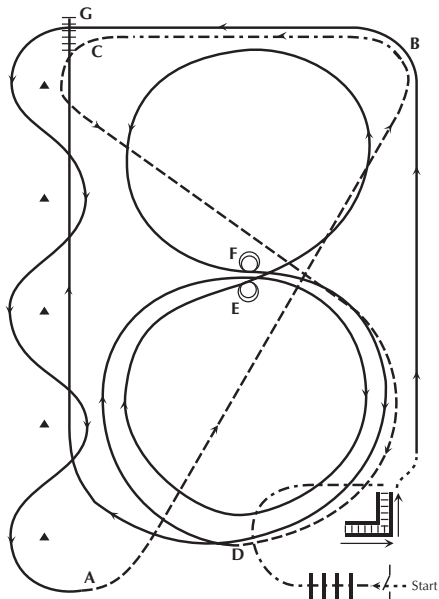

Walk	.....	Back	
Jog	-----		
Extended Jog	-----		
Lope	—————	Cone	▲